

JACKSONVILLE 1

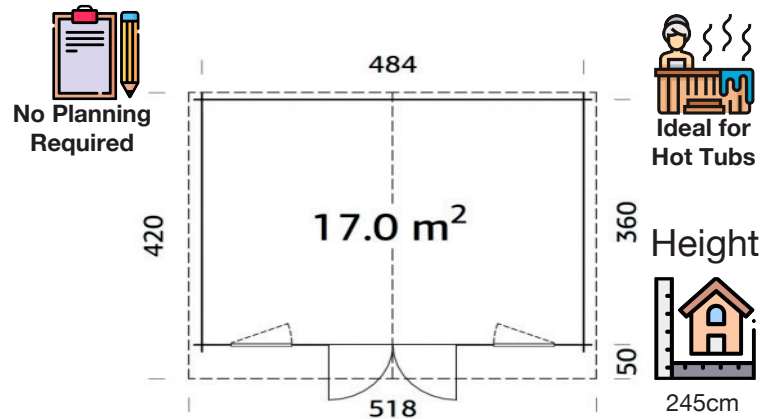

The Jacksonville 1 log cabin made with 28mm logs finished off with traditional windows and an Apex roof. Jacksonville 1 would make an excellent workshop or attractive storage cabin in your garden. Alternatively, purchasing the optional floor boards perfect as an outside family room for the children's painting and messy play or as a grown-up living space to relax in after a busy week.



504 x 380cm



28mm



36.3m³



17.0m²



139 x 175cm



66 x 89cm (x 2)



Not Included-Optional



16mm



50 cm

FULL SPECIFICATION

CABIN SIZE:	504 x 380cm x 245cm	Wood Type:	Nordic Spruce
WALL THICKNESS:	28mm	Chalet Cut:	Logs (Wind & Rain Protection)
VOLUME:	36.3m³	Window Type:	4mm
AREA:	17.0m²	Window / Door Feature:	Window With Water Gutter
DOOR OPENING:	139 x 175cm	Braces:	Wind Braces
WINDOW OPENING:	66 x 89cm (x 2)	Roof Boards With:	Boards With Tongue & Groove
FLOORS BOARDS:	Option	Guarantee:	5 Years
ROOF BOARDS:	16mm	Treated Foundation Joists:	No
ROOF OVERHANG:	50cm	IDEAL FOR:	Hot Tub Retreat Log Cabin Log Cottages Games Room Office Study
UNDER PLANNING:	Yes		

FROM £2,865

FINANCE FROM £27.87 PCM

